

分割定位柱精實的 · 含六角形軸環

EH 22110.

產品描述

索引柱塞用於索引鑽孔。
含鎖/不含鎖具有相同高度。
由於螺栓縮回,分割定位柱可以完全被鎖入。

材質

- 本體
- 鋼, 染黑
 - 不銹鋼 1.4305
- 固定梢子
- 鋼, 硬化
 - 不銹鋼 1.4305, 鍍鎳

- 手把
- 塑膠(PA6), 黑色, 無光澤的

組裝

螺絲長度可由分割定位柱襯套調整 (EH 22120.)。

更多資訊

注意事項

不可移動的旋鈕。
螺帽必須個別購買。

更多產品

- 支持座, 用於分割螺栓和分割定位柱, 壓鑄
- 定位襯套, 適用於分割螺栓和分割定位柱
- 距離調整環, 適用於分割定位柱



圖面

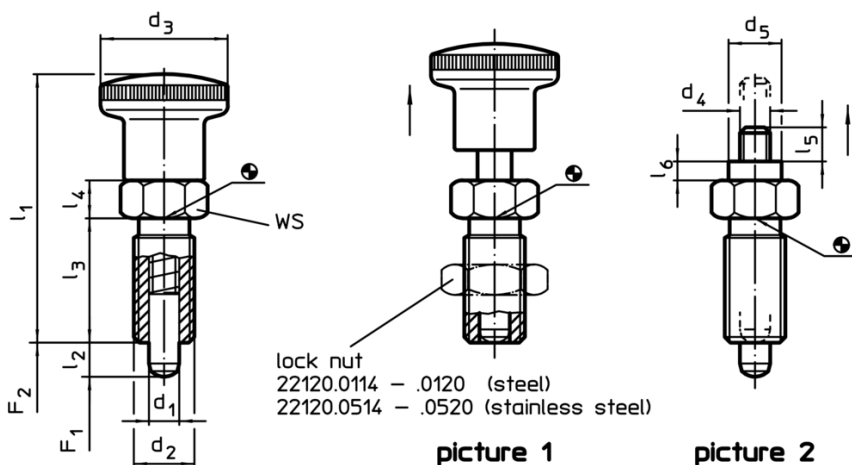

訂單資訊

尺寸											WS	彈簧荷重 ¹⁾		溫度		重量	RoHS	REACH	品號	
d ₁	l ₂	d ₂	d ₃	d ₄	d ₅	l ₁	l ₃	l ₄	l ₅	l ₆		F ₁	F ₂	min	max.	[g]				
-0,02	min										[mm]	~	~	[°C]						
-0,04											[mm]	[N]	[N]	[°C]						
有手把 - 相片 1, 鋼																				
4	4	M 8 x 1	16	-	-	35,0	16	5	-	-	10	4,5	12,0	-30	80	10	RoHS 認證	contains no SVHC materials	22110.0103	
4	6	M 8 x 1	16	-	-	35,0	16	5	-	-	10	4,0	12,5	-30	80	10	RoHS 認證	contains no SVHC materials	22110.0104	
5	5	M10 x 1	19	-	-	40,0	18	6	-	-	12	5,0	15,0	-30	80	18	RoHS 認證	contains no SVHC materials	22110.0106	
5	8	M10 x 1	19	-	-	40,0	18	6	-	-	12	5,0	18,0	-30	80	18	RoHS 認證	contains no SVHC materials	22110.0107	
6	6	M12 x 1,5	23	-	-	48,0	22	6	-	-	14	6,5	19,0	-30	80	29	RoHS 認證	contains no SVHC materials	22110.0109	
6	9	M12 x 1,5	23	-	-	48,0	22	6	-	-	14	6,0	25,0	-30	80	29	RoHS 認證	contains no SVHC materials	22110.0110	
8	8	M16 x 1,5	28	-	-	58,0	26	8	-	-	17	8,5	26,0	-30	80	62	RoHS 認證	contains no SVHC materials	22110.0112	

¹⁾ 統計平均值



d ₁ -0,02 -0,04	l ₂ min	d ₂	d ₃	尺寸							WS [mm]	彈簧荷重 ¹⁾		溫度		重量 [g]	RoHS	REACH	品號
				d ₄	d ₅	l ₁	l ₃	l ₄	l ₅	l ₆		F ₁ ~	F ₂ ~	min	max.				
[mm]											[N]		[°C]		[g]				
8	12	M16 x 1,5	28	-	-	58,0	26	8	-	-	17	8,5	28,0	-30	80	62	RoHS 認證	contains no SVHC materials	22110.0113
10	12	M16 x 1,5	28	-	-	58,0	26	8	-	-	17	9,5	38,0	-30	80	63	RoHS 認證	contains no SVHC materials	22110.0115
12	15	M20 x 1,5	33	-	-	67,0	33	10	-	-	22	11,5	40,0	-30	80	128	RoHS 認證	contains no SVHC materials	22110.0116
16	20	M24 x 2	33	-	-	78,5	38	12	-	-	27	13,0	54,0	-30	80	204	RoHS 認證	contains no SVHC materials	22110.0117
無手把 – 相片 2, 鋼																			
4	4	M 8 x 1	-	M3	7	-	16	5	4,5	2,5	10	4,5	12,0	-	250	9	RoHS 認證	contains no SVHC materials	22110.0143
4	6	M 8 x 1	-	M3	7	-	16	5	4,5	2,5	10	4,0	12,5	-	250	9	RoHS 認證	contains no SVHC materials	22110.0144
5	5	M10 x 1	-	M4	8	-	18	6	5,5	3,0	12	5,0	15,0	-	250	16	RoHS 認證	contains no SVHC materials	22110.0146
5	8	M10 x 1	-	M4	8	-	18	6	5,5	3,0	12	5,0	18,0	-	250	16	RoHS 認證	contains no SVHC materials	22110.0147
6	6	M12 x 1,5	-	M5	9	-	22	6	7,0	3,5	14	6,5	19,0	-	250	25	RoHS 認證	contains no SVHC materials	22110.0149
6	9	M12 x 1,5	-	M5	9	-	22	6	7,0	3,5	14	6,0	25,0	-	250	25	RoHS 認證	contains no SVHC materials	22110.0150
8	8	M16 x 1,5	-	M6	10	-	26	8	8,5	4,0	17	8,5	26,0	-	250	55	RoHS 認證	contains no SVHC materials	22110.0152
8	12	M16 x 1,5	-	M6	10	-	26	8	8,5	4,0	17	8,5	28,0	-	250	55	RoHS 認證	contains no SVHC materials	22110.0153
10	12	M16 x 1,5	-	M6	10	-	26	8	8,5	4,0	17	9,5	38,0	-	250	56	RoHS 認證	contains no SVHC materials	22110.0155
12	15	M20 x 1,5	-	M6	12	-	33	10	8,5	4,0	22	11,5	40,0	-	250	111	RoHS 認證	contains no SVHC materials	22110.0156
16	20	M24 x 2	-	M8	15	-	38	12	11,5	5,0	27	13,0	54,0	-	250	194	RoHS 認證	contains no SVHC materials	22110.0157
有手把 – 相片 1, 不銹鋼																			
4	4	M 8 x 1	16	-	-	35,0	16	5	-	-	10	4,5	12,0	-30	80	10	RoHS 認證	contains no SVHC materials	22110.0203
4	6	M 8 x 1	16	-	-	35,0	16	5	-	-	10	4,0	12,5	-30	80	10	RoHS 認證	contains no SVHC materials	22110.0204
5	5	M10 x 1	19	-	-	40,0	18	6	-	-	12	5,0	15,0	-30	80	18	RoHS 認證	contains no SVHC materials	22110.0206
5	8	M10 x 1	19	-	-	40,0	18	6	-	-	12	5,0	18,0	-30	80	18	RoHS 認證	contains no SVHC materials	22110.0207
6	6	M12 x 1,5	23	-	-	48,0	22	6	-	-	14	6,5	19,0	-30	80	29	RoHS 認證	contains no SVHC materials	22110.0209
6	9	M12 x 1,5	23	-	-	48,0	22	6	-	-	14	6,0	25,0	-30	80	29	RoHS 認證	contains no SVHC materials	22110.0210
8	8	M16 x 1,5	28	-	-	58,0	26	8	-	-	17	8,5	26,0	-30	80	62	RoHS 認證	contains no SVHC materials	22110.0212
8	12	M16 x 1,5	28	-	-	58,0	26	8	-	-	17	8,5	28,0	-30	80	62	RoHS 認證	contains no SVHC materials	22110.0213
10	12	M16 x 1,5	28	-	-	58,0	26	8	-	-	17	9,5	38,0	-30	80	63	RoHS 認證	contains no SVHC materials	22110.0215
12	15	M20 x 1,5	33	-	-	67,0	33	10	-	-	22	11,5	40,0	-30	80	128	RoHS 認證	contains no SVHC materials	22110.0216
16	20	M24 x 2	33	-	-	78,5	38	12	-	-	27	13,0	54,0	-30	80	204	RoHS 認證	contains no SVHC materials	22110.0217
無手把 – 相片 2, 不銹鋼																			
4	4	M 8 x 1	-	M3	7	-	16	5	4,5	2,5	10	4,5	12,0	-	250	9	RoHS 認證	contains no SVHC materials	22110.0243
4	6	M 8 x 1	-	M3	7	-	16	5	4,5	2,5	10	4,0	12,5	-	250	9	RoHS 認證	contains no SVHC materials	22110.0244
5	5	M10 x 1	-	M4	8	-	18	6	5,5	3,0	12	5,0	15,0	-	250	16	RoHS 認證	contains no SVHC materials	22110.0246

¹⁾ 統計平均值

d ₁ -0,02 -0,04	l ₂ min	d ₂	尺寸									WS [mm]	彈簧荷重 ¹⁾		溫度		RoHS	REACH	品號
			d ₃	d ₄	d ₅	l ₁	l ₃	l ₄	l ₅	l ₆	F ₁ ~		F ₂ ~	min	max.				
[mm]											[mm]	[N]	[°C]		[g]				
5	8	M10 x 1	-	M4	8	-	18	6	5,5	3,0	12	5,0	18,0	-	250	16	RoHS 認證	contains no SVHC materials	22110.0247
6	6	M12 x 1,5	-	M5	9	-	22	6	7,0	3,5	14	6,5	19,0	-	250	25	RoHS 認證	contains no SVHC materials	22110.0249
6	9	M12 x 1,5	-	M5	9	-	22	6	7,0	3,5	14	6,0	25,0	-	250	25	RoHS 認證	contains no SVHC materials	22110.0250
8	8	M16 x 1,5	-	M6	10	-	26	8	8,5	4,0	17	8,5	26,0	-	250	55	RoHS 認證	contains no SVHC materials	22110.0252
8	12	M16 x 1,5	-	M6	10	-	26	8	8,5	4,0	17	8,5	28,0	-	250	55	RoHS 認證	contains no SVHC materials	22110.0253
10	12	M16 x 1,5	-	M6	10	-	26	8	8,5	4,0	17	9,5	38,0	-	250	56	RoHS 認證	contains no SVHC materials	22110.0255
12	15	M20 x 1,5	-	M6	12	-	33	10	8,5	4,0	22	11,5	40,0	-	250	111	RoHS 認證	contains no SVHC materials	22110.0256
16	20	M24 x 2	-	M8	15	-	38	12	11,5	5,0	27	13,0	54,0	-	250	194	RoHS 認證	contains no SVHC materials	22110.0257

¹⁾ 統計平均值

配件

	尺寸 d ₂ [mm]	扳手尺寸 [mm]	重量 [g]	RoHS	REACH	品號
鎖緊螺帽 ISO 8675(DIN 439) 適用於下列尺寸, 鋼						
	M 8 x 1	13	2,7	RoHS 認證	contains no SVHC materials	22120.0114
	M10 x 1	16	5,2	RoHS 認證	contains no SVHC materials	22120.0115
	M12 x 1,5	18	7,4	RoHS 認證	contains no SVHC materials	22120.0116
	M16 x 1,5	24	18,0	RoHS 認證	contains no SVHC materials	22120.0118
	M20 x 1,5	30	32,0	RoHS 認證	contains no SVHC materials	22120.0120
	M24 x 2	36	58,0	RoHS 認證	contains no SVHC materials	22120.0122
鎖緊螺帽 ISO 8675(DIN 439) 適用於下列尺寸, 不銹鋼						
	M 8 x 1	13	2,7	RoHS 認證	contains no SVHC materials	22120.0514
	M10 x 1	16	5,2	RoHS 認證	contains no SVHC materials	22120.0515
	M12 x 1,5	18	7,4	RoHS 認證	contains no SVHC materials	22120.0516
	M16 x 1,5	24	18,0	RoHS 認證	contains no SVHC materials	22120.0518
	M20 x 1,5	30	32,0	RoHS 認證	contains no SVHC materials	22120.0520
	M24 x 2	36	58,0	RoHS 認證	contains no SVHC materials	22120.0522

應用範例

