

ASC

氣壓轉角缸

ASC PNEUMATIC SWING CLAMP



產品特性

本產品適用於量產零件之專用機及MC治具，提高生產效率的幫手。
 主要功能為氣壓缸作動時，活塞下壓行程中壓板會旋轉到設計的角度，再沿著直線繼續下壓直到壓板夾緊工件。
 建議使用氣壓轉角缸，請加裝流量控制閥，避免速度過快，以及轉角行程中，請勿夾持工件，導致損壞缸體及內部零件。
 缸體材質採用鋁合金，表面硬膜處理，內壁表面光滑，使用壽命長。

最大操作壓力：7 kgf/cm²
 最小操作壓力：4 kgf/cm²
 作動方式：複動式

注意事項

夾緊及放鬆作動速度需適當放緩。
 特殊壓臂長度及重量不得超過標準壓臂的1.5倍。壓臂旋轉示意圖及安裝拆卸方式，請參見第4頁。

FEATURES

This machine with MC clamp is exclusively to mass-produce spare parts. It is a big helper to raise production efficiency. The clamping arm of this clamp will swing around the angle when the piston traveling down, and then keep straight on until the clamping arm clamps the work-piece tightly.
 You had better install a flow control valve to adjust the acting speed, and don't clamp the workpiece when the clamp is running. Otherwise will be easy to damage the body and the spare parts.
 The material of the cylinder body is made of aluminum metal alloy, the surface is processed with the hard membrane and the inside of it is smooth. It is long-lived to use.

Max. operating pressure: 7 kgf/cm²
 Min. operating pressure: 4 kgf/cm²
 Double acting

NOTE

The speed of clamping and unclamping action needs to be slowed down appropriately. The length and weight of the customized clamping arm shall not exceed 1.5 times of the standard clamping arm.
 Please refer to Page 4 for installation instructions or removal methods of the clamping arm. Customization is available upon request, please contact us for more info.

剖面圖 Sectional view

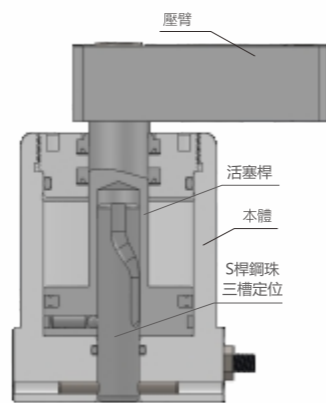

配管式LineType-S

Single side swing clamp

配管式LineType-D

Double side swing clamp
 註：下圖為轉角90°鬆開狀態

深孔型附調速MF-S

Single side swing clamp

深孔型附調速MF-D

Double side swing clamp
 註：下圖為轉角90°鬆開狀態

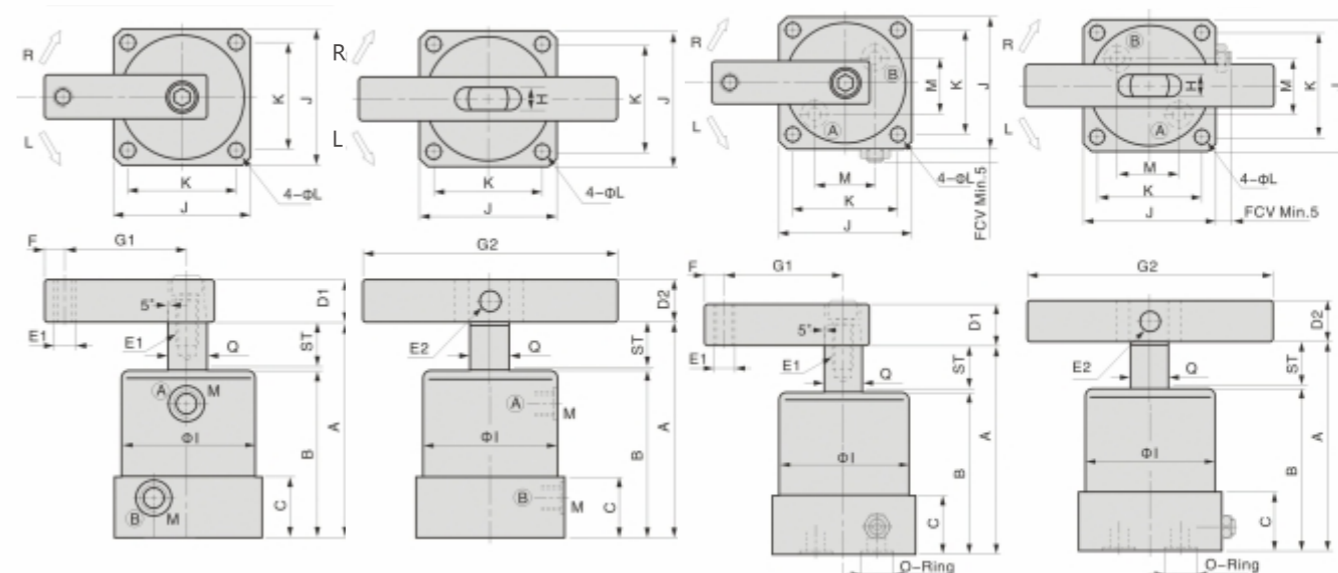

- Ⓐ 夾持氣孔 Clamping port
- Ⓑ 放鬆氣孔 Unclamping port

Unit:mm

MODEL	ST:Swing /Clamping	A鬆開狀態 /Unclamp	B	C	D1	D2	E1	E2	F	G1	G2	H	ΦI	J	K	L	M	O-RING	Q
ASC-25	22:9/13	89	65	23	□16	-	M6×1.0	-	6	35	-	-	Φ35	38	30	Φ4.6	M5×0.8	-	Φ14
ASC-32	26:11/15 41:11/30	108 138	78 93	28	□19	□19	M8×1.25	Φ8	8	50	140	9	Φ46	50	40	Φ5.6	PT1/8	-	Φ16
ASC-40	26:11/15 41:11/30	108 138	78 93	28	□19	□19	M8×1.25	Φ8	8	55	140	9	Φ55	60	48	Φ6.8	PT1/8	-	Φ16
ASC-50	30:13/17 47:13/34	124 158	90 107	31	□25	□22	M10×1.5	Φ8	10	60	160	10	Φ65	70	57	Φ6.8	PT1/8	-	Φ20
ASC-63	30:13/17 47:13/34	124 158	90 107	31	□25	□22	M10×1.5	Φ8	10	70	160	10	Φ78	83	67	Φ9	PT1/8	-	Φ20
ASC-MF32	26:11/15	108	78	22	□19	□19	M8×1.25	Φ8	8	50	140	9	Φ46	50	40	Φ5.6	19	P7	Φ16
ASC-MF40	26:11/15	108	78	22	□19	□19	M8×1.25	Φ8	8	55	140	9	Φ55	60	48	Φ6.8	23	P7	Φ16
ASC-MF50	30:13/17	124	90	25	□25	□22	M10×1.5	Φ8	10	60	160	10	Φ65	70	57	Φ6.8	28	P9	Φ20
ASC-MF63	30:13/17	124	90	25	□25	□22	M10×1.5	Φ8	10	70	160	10	Φ78	83	67	Φ9	32	P9	Φ20

規格參數表 SPECIFICATIONS

型號	理論夾持力 (7kgf/cm ²)	轉角行程	夾緊行程	總行程	推出容積	拉入容積	推出受壓面積	拉入受壓面積	使用溫度範圍	使用液體
MODEL	CLAMPING FORCE AT 7kgf/cm ² (kgf)	Swing stroke (mm)	CLAMPING STROKE (mm)	TOTAL STROKE(mm)	CYLINDER CAPACITY UNCLAMP(cm ³)	CYLINDER CAPACITY CLAMP(cm ³)	EFF.PISTON AREA UNCLAMP(cm ²)	EFF.PISTON AREA CLAMP(cm ²)	RANGE OF TEMPERATURE(°C)	USABLE FLUID
ASC-25	24	9	13	22	12.28	7.41	4.91	3.37	-10~+60°C	過濾之乾燥壓縮空氣 Filtered dry compressed air
ASC-32	42	11	15/30	26/41	20.9/32.96	15.68/24.73	8.04	6.03	-10~+60°C	
ASC-40	74	11	15/30	26/41	32.66/51.5	27.43/43.26	12.56	10.55	-10~+60°C	
ASC-50	115	13	17/34	30/47	58.89/92.26	49.47/77.5	19.63	16.49	-10~+60°C	
ASC-63	196	13	17/34	30/47	93.48/146.45	84.06/131.69	31.16	28.02	-10~+60°C	

感應式MS25S

Single side swing clamp

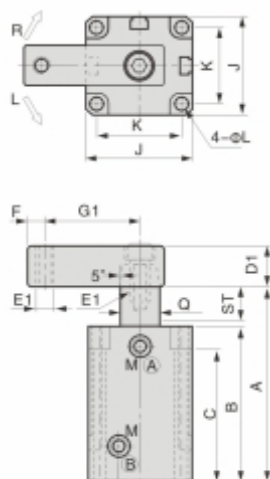

感應式MS32S-63S

Single side swing clamp

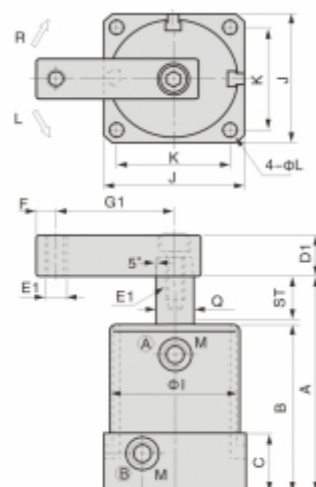

感應式MS32D-63D

Double side swing clamp
註：下圖為轉角90°鬆開狀態

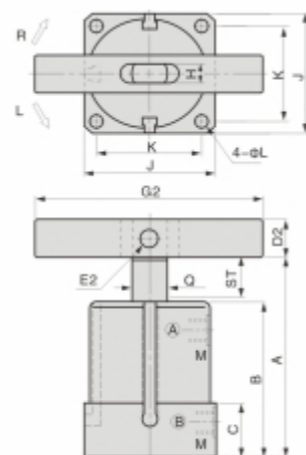

法蘭型FA-S

Single side swing clamp

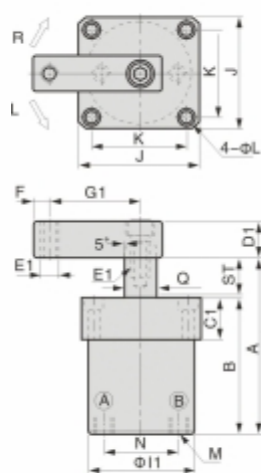

法蘭型FA-D

Double side swing clamp
註：下圖為轉角90°鬆開狀態

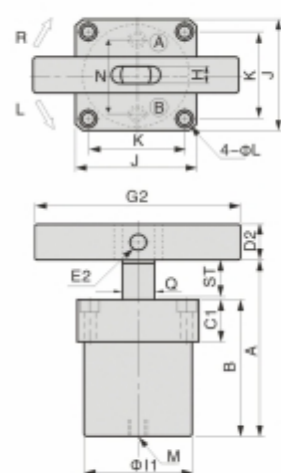

全牙型TB-S

Single side swing clamp

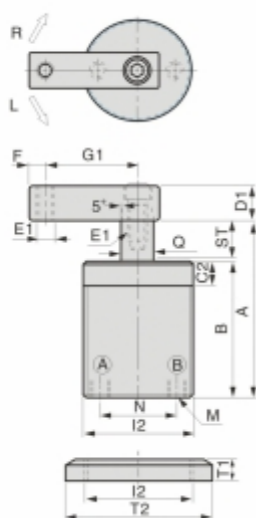

全牙型TB-D

Double side swing clamp
註：下圖為轉角90°鬆開狀態

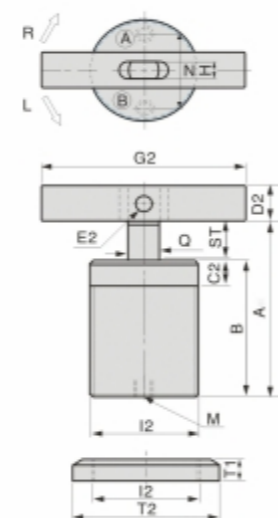

Ⓐ 夾持氣孔 Clamping port Ⓑ 放鬆氣孔 Unclamping port

Unit:mm

MODEL	ST:Swing /Clamping	A鬆開狀態 /Unclamp	B	C1	C2	D1	D2	E1	E2	F	G1	G2	H	φ11	I2	J	K	L	M	N	T1×2PCS	T2	Q
ASC-FA32 ASC-TB32	26:11/15	108	78	22	12	□19	□19	M8×1.25	φ8	8	50	140	9	φ46	M50×1.5	50	40	φ5.6-φ9×5.5D	PT1/8	32	11	φ70	φ16
ASC-FA40 ASC-TB40	26:11/15	108	78	22	12	□19	□19	M8×1.25	φ8	8	55	140	9	φ55	M55×1.5	60	48	φ6.8-φ10.5×6.5D	PT1/8	40	11	φ75	φ16
ASC-FA50 ASC-TB50	30:13/17	124	90	25	15	□25	□22	M10×1.5	φ8	10	60	160	10	φ65	M65×1.5	70	57	φ6.8-φ10.5×6.5D	PT1/8	50	12	φ85	φ20
ASC-FA63	30:13/17	124	90	25	-	□25	□22	M10×1.5	φ8	10	70	160	10	φ78	-	83	67	φ9-φ14×9D	PT1/8	63	-	-	φ20

Unit:mm

MODEL	ST:Swing /Clamping	A鬆開狀態 /Unclamp	B	C	D1	D2	E1	E2	F	G1	G2	H	φI	J	K	L	M	Q
ASC-MS25	22:9/13	94	70	60	□16	-	M6×1.0	-	6	35	-	-	φ35	38	30	φ4.6	M5×0.8	φ14
ASC-MS32	26:11/15	113	83	28	□19	□19	M8×1.25	φ8	8	50	140	9	φ46	50	40	φ5.6	PT1/8	φ16
ASC-MS40	26:11/15	113	83	28	□19	□19	M8×1.25	φ8	8	55	140	9	φ55	60	48	φ6.8	PT1/8	φ16
ASC-MS50	30:13/17	129	95	31	□25	□22	M10×1.5	φ8	10	60	160	10	φ65	70	57	φ6.8	PT1/8	φ20
ASC-MS63	30:13/17	129	95	31	□25	□22	M10×1.5	φ8	10	70	160	10	φ78	83	67	φ9	PT1/8	φ20

