

CTK

夾緊氣缸

CTK CLAMPING CYLINDER



產品特性

氣缸缸體使用鋁合金材料，經氧化鋁處理，更具耐磨及耐腐蝕性。採用無給油軸承及耐磨密封環使用壽命長。

多個配管位置可供選擇。

附緩衝型可有效減緩封缸蓋之衝擊。

附磁性環型可搭配選用磁簧開關。

FEATURES

The body of the cylinder is made of aluminum alloy, after the vaporization of aluminum processing, it is more wear resistance and corrosion resistance. With the no oil bearing and wear-resisting sealing ring, the cylinder has a long service life. Multiple piping position to choose.

The cylinder with the buffer action can effectively slow speed and weaken the impact force on the cylinder head.

The cylinder with a magnetic ring can match with magnetic reed switch.

最大操作壓力：10 kgf/cm²

最小操作壓力：1 kgf/cm²

作動方式：複動式

Max. operating pressure: 10 kgf/cm²

Min. operating pressure: 1 kgf/cm²

Double acting

訂購標示法 ORDERING INDICATION

示例：CTK-50-100MY

CTK	系列	CTK	
50	氣缸內徑 Cylinder inside diameter	Φ50, Φ63	
100	行程 Stroke	50, 75, 100, 125, 150	
M	附磁石 With magnet	無：無附磁石 M：附磁石	Nil: without magnet M: Magnet
Y	接頭配件 Accessory	無 Y：Y接頭 I：I接頭	Nil: no accessory Y: Y joint I: I joint

使用流體：過濾之乾燥壓縮空氣
Usable fluid: Oiled Dry Clean Compressed Air

使用範例

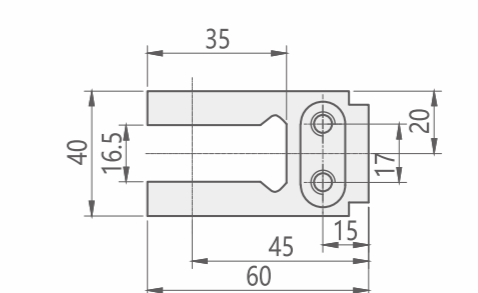
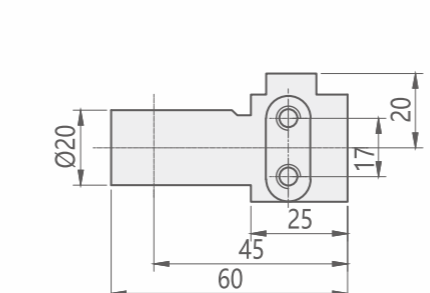
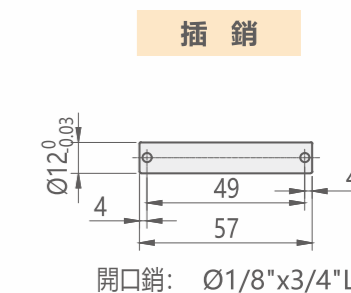
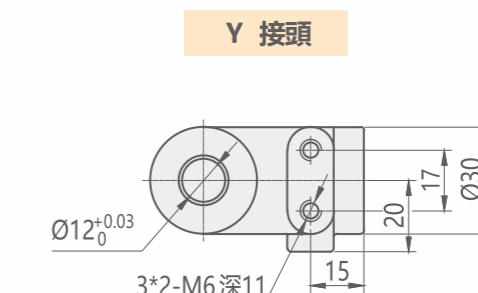
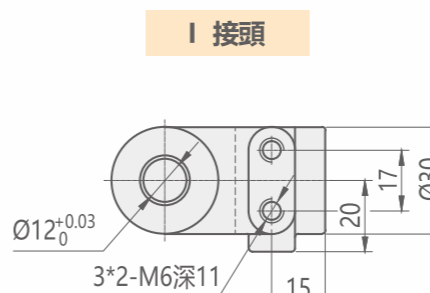
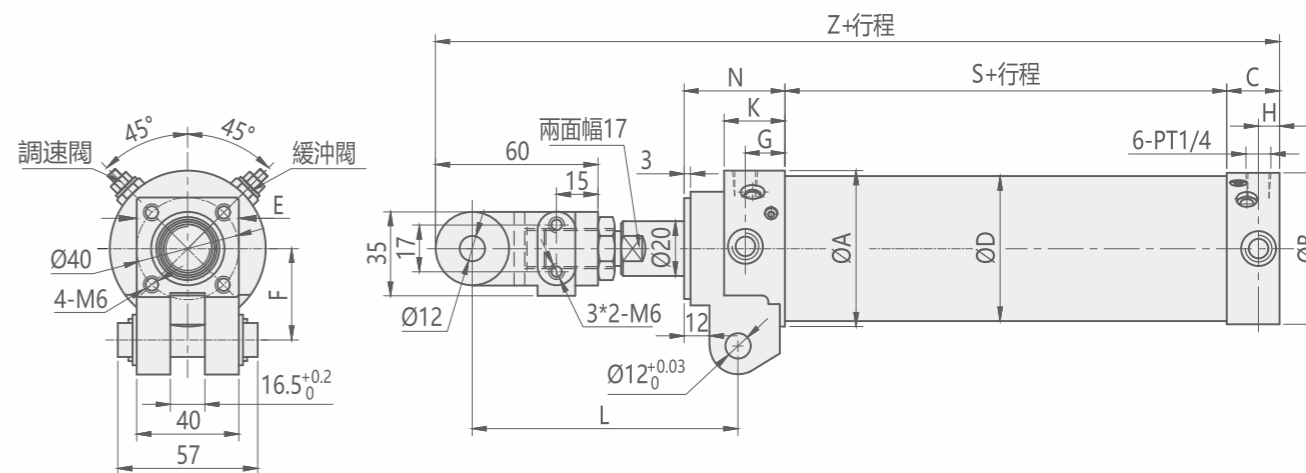
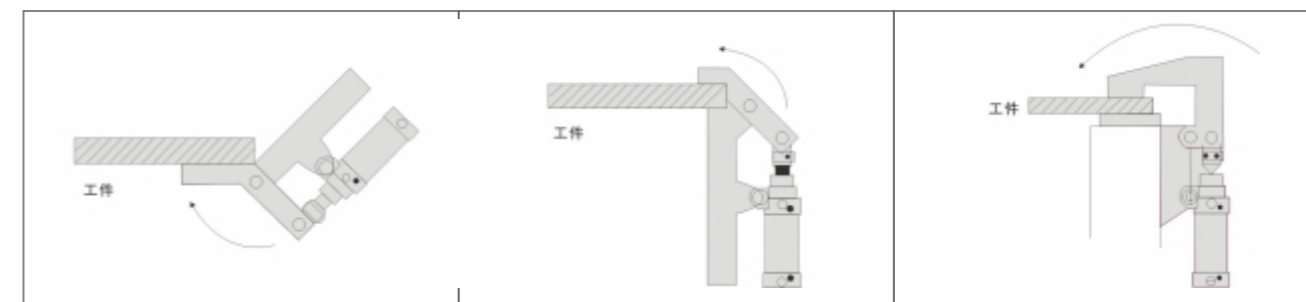

Unit:mm

缸徑BORE	ΦA	ΦB	ΦD	C	E	F	G	H	K	N	L	S	Z
50	60	58	58	25	40	36	19	10	29	48	97	46	205
63	74	72	69	25	50	36	19	10	29	48	97	46	205