

# PB

## 感應式氣壓轉角缸

# PB PNEUMATIC SWING CLAMP



### 產品特性

設計簡單，結構緊湊，重量輕，壽命長以及高的夾持力使它成為一種好的夾具。本產品有長行程及短行程兩種可任意選擇上面和下面安裝。廣泛應用於工業自動化，例如：薄片金屬的夾持、輸送帶上工件的夾緊輸送，以及包裝流水線作業。

最大操作壓力：7 kgf/cm<sup>2</sup>  
 最小操作壓力：4 kgf/cm<sup>2</sup>  
 作動方式：複動式

### 注意事項

夾緊及放鬆作動速度需適當放緩。特殊壓臂長度及重量不得超過標準壓臂的1.5倍。壓臂旋轉示意圖及安裝拆卸方式，請參見第4頁。

### 訂購標示法 ORDERING INDICATION

示例：PBS-40R-90-S2

PB	系列 Series	PB
S	行程 Stroke	長行程L: Long stroke 短行程S: Short stroke
40	氣缸內徑 Cylinder inside diameter	Φ25, Φ32, Φ40, Φ50
R	轉角方向 Rotating direction	右轉R或左轉L Turn right or turn left
90	轉角角度 Rotating angle	標準角度 Standard angle 90° (±2°) 訂做角度 Order angle 0°, 45° (±2°), 60° (±2°)
S2	感應開關 Sensor switch	S1: 1個 S1:1 pc of S1 S2: 2個 S2:2 pcs of S2

### FEATURES

Simple and compact structure, lightweight, high clamping capacity, and long product lifespan. This series has the option of choosing a long or a short stroke, which can be installed at the top or the bottom. It is widely used in industrial automation, such as clamping of sheet metal, clamping of workpieces on conveyor belts, and packaging assembly line operations.

Max. operating pressure: 7 kgf/cm<sup>2</sup>  
 Min. operating pressure: 4 kgf/cm<sup>2</sup>  
 Double acting

### 剖面圖 Sectional view

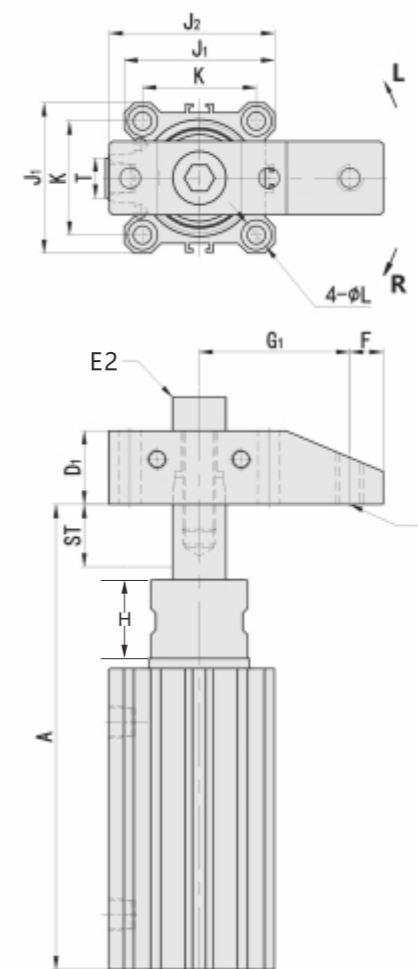
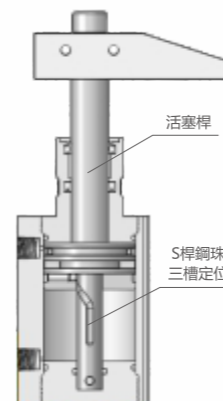

Ⓐ 夾持氣孔 Clamping port  
 Ⓑ 放鬆氣孔 Unclamping port

### 規格參數表 SPECIFICATIONS

型號	理論夾持力 (7kgf/cm <sup>2</sup> )	轉角行程	夾緊行程	總行程	拉入容積	推出容積	拉入受壓面積	推出受壓面積	使用溫度範圍	使用流體
MODEL	CLAMPING FORCE AT 7kgf/cm <sup>2</sup> (kgf)	Swing stroke (mm)	CLAMPING STROKE (mm)	TOTAL STROKE(mm)	CYLINDER CAPACITY CLAMP(cm <sup>3</sup> )	CYLINDER CAPACITY UNCLAMP(cm <sup>3</sup> )	EFF.PISTON AREA CLAMP(cm <sup>2</sup> )	EFF.PISTON AREA UNCLAMP(cm <sup>2</sup> )	RANGE OF TEMPERATURE(°C)	USABLE FLUID
PBS-25	24	9.5	10	19.5	6.57	9.57	3.37	4.91	-10~+60°C	過濾之乾燥壓縮空氣 Filtered dry compressed air
PBL-25	24	9.5	20	29.5	9.94	14.48	3.37	4.91	-10~+60°C	
PBS-32	42	15	10	25	15.05	20.10	6.02	8.04	-10~+60°C	
PBL-32	42	15	20	35	21.07	28.14	6.02	8.04	-10~+60°C	
PBS-40	74	15	10	25	26.40	31.40	10.56	12.56	-10~+60°C	
PBL-40	74	15	20	35	36.96	43.96	10.56	12.56	-10~+60°C	
PBS-50	116	19	20	39	64.35	76.56	16.5	19.63	-10~+60°C	
PBL-50	116	19	50	69	113.85	135.45	16.5	19.63	-10~+60°C	

Unit:mm

MODEL	ST:Swing /Clamping	A鬆開狀態 /Unclamp	B	C	D1	E1	E2	F	G1	H	J1	J2	K	L	M	N1	N2	Q	Q1	Q2	T
PBS-25	19.5:9.5/10	109	73	3	□16	M6	M8	7	32	9	40	42	28	Φ5.5-Φ9×9D	M5	16.5	14	Φ14	Φ26	Φ25	11
PBL-25	29.5:9.5/20	129	83	3	□22	M8	M10	10	45	23.5	45	49.5	34	Φ5.5-Φ9×9D	PT1/8	16.5	16	Φ16	Φ30	Φ29	14.8
PBS-40	25:15/10	134.5	80	3	□22	M8	M10	10	45	24.5	52	57	40	Φ5.5-Φ9×12D	PT1/8	19	16	Φ16	Φ30	Φ29	14.8
PBL-40	35:15/20	154.5	90	3.5	□25	M10	M12	10	65	39	64	71	50	Φ6.6-Φ11×13D	PT1/4	24	17	Φ20	Φ37	Φ36	20